

PLANTS AUDITS, DEBOTTLENECKING AND EFFICIENCY IMPROVEMENT

thanks to DSEC's Factory Audits and INTEGRATED PREDICTIVE MODEL (DSEC IPM[®])

Understanding why a plant is not performing as expected or improving performances of an existing unit can only be done efficiently by analysing how the plant should be performing in its current configuration and how it would perform if modifications are provided.

To do so, DSEC has developed a fully Integrated **Predictive Simulation tool (DSEC IPM[®])** running on MATLAB[®] and SIMULINK[®] software allowing to simultaneously consolidate the Mass and Heat Balances as well as to predict the colour transfer throughout the growth of the sugar crystal layers. The **DSEC IPM[®]** can reproduce the plant set-up and simulate the consequences of any planned modification with a view of improving plant performances further to an in-depth site audit:

- ✓ Capacity Increase
- ✓ Yield improvement
- ✓ Energy consumption improvement
- ✓ Color optimization

It is based on **Physical Parameters and Mathematic Models** (no preset values or ratios) and provides data that can be used for the plant operation, **covering the full process:**

- ✓ Diffusion / Extraction
- ✓ Juice Purification
- ✓ Juice Heating and Evaporation
- ✓ Crystallization
- ✓ Centrifugation
- ✓ Drying
- ✓ Boiler and Power House

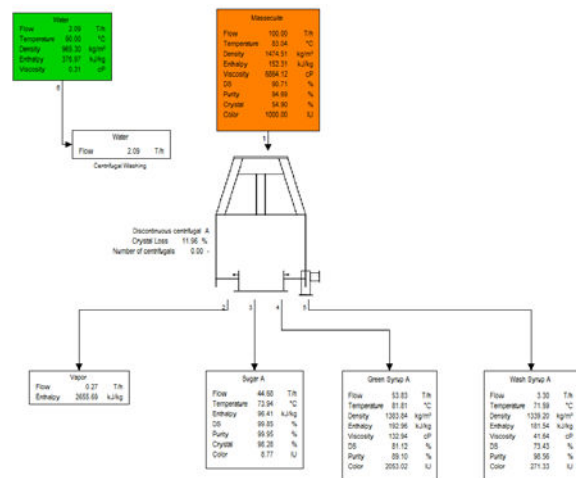
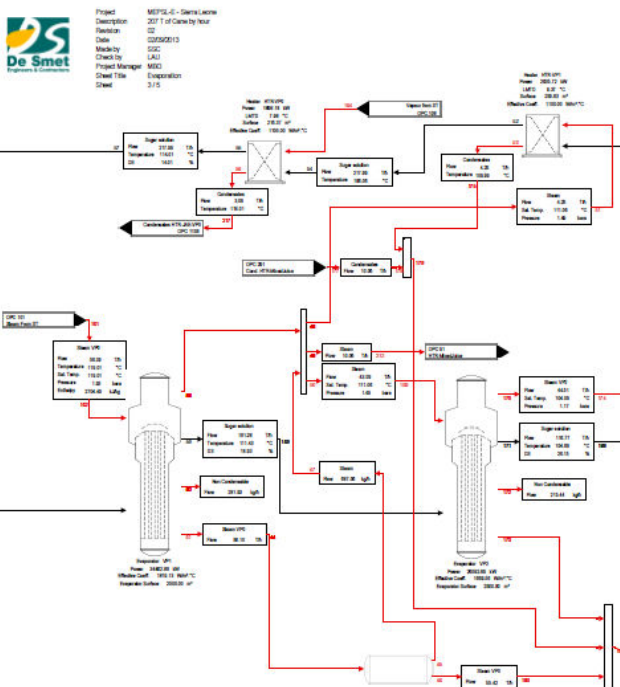
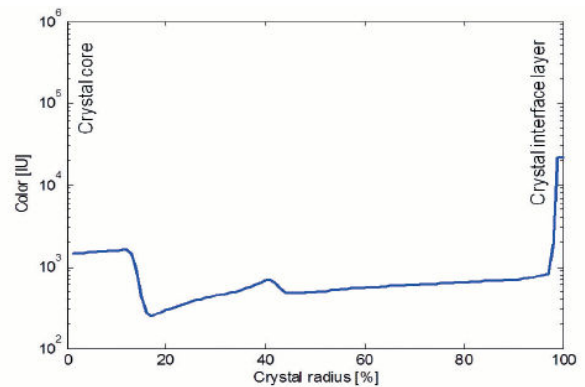

Reliability through Experience



DSEC's Recent Plants Audits with Elaboration of Integrated Predictive Model (Sugar Plants and Refineries)

PRODUCT	CUSTOMER	COUNTRY	OBJECT	YEAR
BEET	Tereos - Connantre	France	Full Sizing of Crystallization Plant	2016
BEET	Raffinerie Tirlémontoise (Südzucker Group) - Wanze	Belgium	Evaporation Audit	2016
CANE	Dangote Sugar Refinery	Nigeria	Full Sugar Refinery Audit (Phase 2)	2015
CANE	Omnicané - Savannah	Mauritius	Full Sugar Plant Audit	2015
CANE	Undisclosed	Undisclosed	Reorganization of Crystallization Plant	2015
BEET	Pfeifer & Langen - Euskirchen	Germany	Energy Efficiency Improvement	2015
BEET	Tereos - Ludus	Romania	Analysis of Pulp Dehydration Plant	2015
BEET	Tereos - Chevières	France	Full Sizing of Crystallization Plant	2015
CANE	Açúcar Guarani – Cruz Alta (Tereos Group)	Brazil	Energy Efficiency Improvement Analysis	2015
CANE	SOMDIAA	Chad	Evaporation and Crystallization Plants Audit	2015
BEET	Tereos - Ludus	Romania	Reorganization of Crystallization Plant	2014
CANE	Dangote Sugar Refinery	Nigeria	Full Sugar Refinery Audit (Phase 1)	2014
BEET	Empresa IANSA	Chile	Evaporation Plant Analysis	2014
BEET	Raffinerie Tirlémontoise (Südzucker Group) - Wanze	Belgium	Crystallization Plant Improvement Analysis	2014
CANE	SOMDIAA	Gabon	Sugar Plant capacity increase analysis	2013
CANE	Tereos – Bois Rouge	Reunion	Reorganization of Crystallization Plant	2012

In addition DSEC's Integrated Predictive Model is systematically used for the development of all DSEC's turnkey projects around the world (EPC / EPCM).

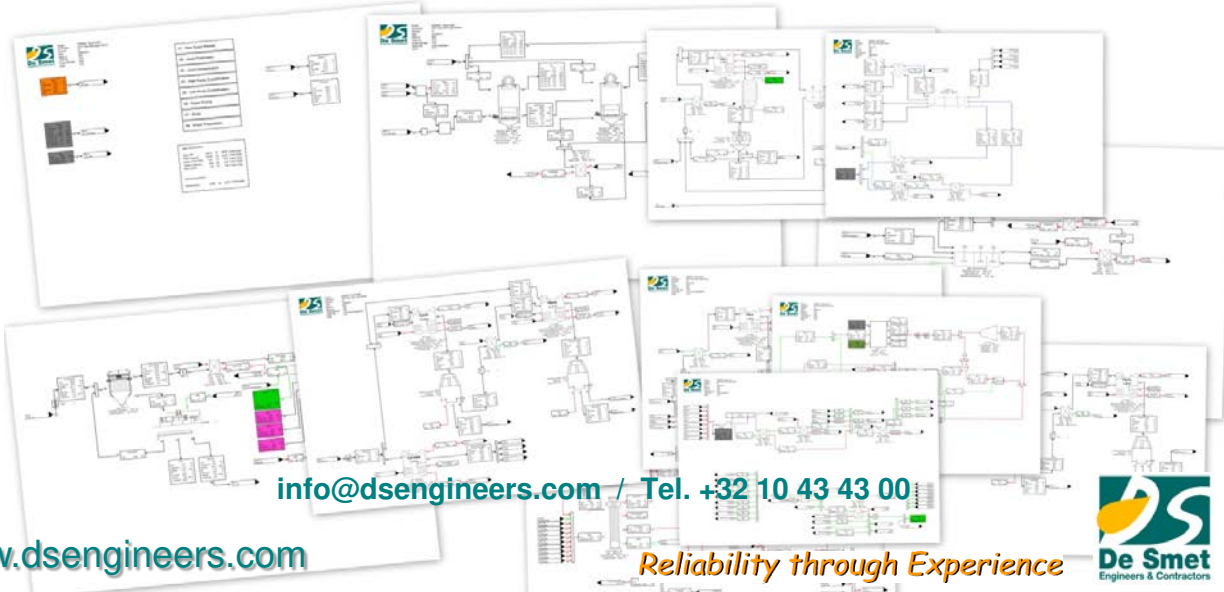

info@dsengineers.com / Tel. +32 10 43 43 00

www.dsengineers.com

Reliability through Experience

